

LIBRA

para ocho instrumentistas

Ricardo Rozzi



INDICACIONES

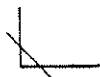

debe tocarse lo más rápido posible

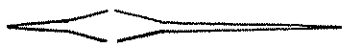

"enflé", el crescendo se realiza durante la primera negra.

Los valores escritos sobre la banda central negra entre los compases 21 y 80 indican los batidos de dirección.

Las alteraciones afectan sólo a la nota que preceden.

Todos los instrumentos están escritos en notas reales.

INSTRUMENTOS

Flauta

Clarinete bajo en Sib

Trompeta en Do (sordinas straight y harmond abierta)

Corno en Fa (sordinas de cartón y metálica)

Violín

Violoncello

Xilorimba

2 Vibráfonos (2 arcos de contrabajo)

Marimba

4 Wood-blocks (agudo, medio-agudo, medio-grave, grave)

4 Cencerros (agudo, medio-agudo, medio-grave, grave)

4 Platillos (agudo, medio-agudo, medio-grave, grave)

2 Bongoes (agudo, grave)

2 Tom-toms (agudo, grave)

DISPOSICION DE LOS INSTRUMENTOS

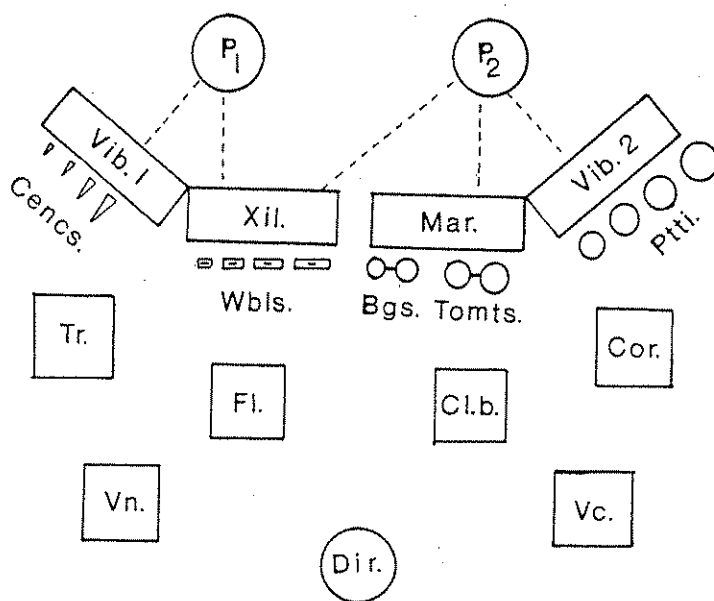

LIBRA

R. Rozzi

para ocho instrumentistas

a Mary Kalin y Juan Armesto

$\text{♩} = 80$

1 2 3

Flauta *f* sempre

Clarinete bajo en Si b *p* sempre

Trompeta en Do *f* sempre
sordina straight
sordina de cartón

Corno en Fa *p* sempre

Violín *f* sempre
sul pont.

Violoncello *f* sempre
port.

Perc. 2 Xilorimba *f* sempre

4 Woodblocks

Perc. 1 Vibráfono 1 *f* sempre

4 Cencerros

Vibráfono 2

4 Piatti

Marimba

2 Bongoes
2 Tom-toms

This musical score page, numbered 2, features eight staves for various instruments. The Flute (Fl.) staff begins with a measure marked '4' and includes fingerings '5' and '6'. The Clarinet in Bass (Cl.b.) staff has a 'b' marking. The Trumpet (Tr.) staff has a 'v' marking. The Horn (Cor.) staff has a 'b' marking. The Violin (Vn.) staff has a 'v' marking. The Viola (Vc.) staff includes 'port.' markings and a '#'. The Percussion 2 (P₂) Xil. staff has a 'v' marking. The Vibraphone 1 (P₁ Vib.1) staff has a 'v' marking. The score includes various musical notations such as notes, rests, slurs, and dynamic markings.

This musical score page, numbered 3, contains eight staves of music for various instruments. The staves are arranged vertically and labeled on the left as follows:

- Fl.** (Flute): Treble clef, featuring a melodic line with a repeat sign and a first ending bracket labeled '8'.
- Cl.b.** (Clarinet in B-flat): Bass clef, playing a supporting line with slurs and accidentals.
- Tr.** (Trumpet): Treble clef, playing a melodic line with a repeat sign and a first ending bracket labeled '8'.
- Cor.** (Horn): Bass clef, playing a melodic line with slurs and accidentals.
- Vn.** (Violin): Treble clef, playing a melodic line with a repeat sign and a first ending bracket labeled '8'.
- Vc.** (Viola): Bass clef, playing a melodic line with slurs and the instruction 'port.' (portamento).
- P₂ XII.** (Percussion XII): Treble clef, playing a rhythmic pattern with a 'loco' marking and a repeat sign with a first ending bracket labeled '8'.
- P₁ Vib. I.** (Percussion Vib. I): Treble clef, playing a rhythmic pattern with a repeat sign and a first ending bracket labeled '8'.

The score includes various musical notations such as slurs, accents, and dynamic markings like 'port.' and 'loco'. The first ending brackets for the Flute, Trumpet, Violin, and Percussion XII staves are labeled with the number '8'.

10 11 12

Fl.

Cl.b.

Tr.

Cor.

Vn.

Vc.

P₂ XII.

P₁ Vib.1

poco a poco crescendo

poco a poco crescendo

port. poco a poco crescendo port.

8

(7 8)

Detailed description: This is a page of a musical score, page 4, featuring eight staves. The instruments are Flute (Fl.), Clarinet in B-flat (Cl.b.), Trumpet (Tr.), Horn (Cor.), Violin (Vn.), Viola (Vc.), Percussion XII (P₂ XII.), and Vibraphone 1 (P₁ Vib.1). The score is divided into three measures, numbered 10, 11, and 12. The Flute and Clarinet parts have melodic lines with slurs and accents. The Trumpet and Horn parts have more complex rhythmic patterns. The Violin and Viola parts have melodic lines with slurs and accents. The Percussion XII part has a rhythmic pattern. The Vibraphone part has a rhythmic pattern. The score includes dynamic markings such as 'poco a poco crescendo' and 'port.' (portamento). There are also some performance instructions like 'poco a poco crescendo' and 'port.' written below the staves. The page number '4' is in the top left corner. Measure numbers '10', '11', and '12' are above the Flute staff. A measure number '8' is above the Percussion XII staff. A measure number '(7 8)' is below the Vibraphone staff.

Musical score for measures 13-15, featuring the following instruments:

- Fl. (Flute)
- Cl. b. (Clarinet in B-flat)
- Tr. (Trumpet)
- Cor. (Horn)
- Vn. (Violin)
- Vc. (Viola)
- P₂ XII. (Percussion XII)
- P₁ Vib. 1. (Vibraphone 1)

Measure numbers 13, 14, and 15 are indicated at the top of the Flute staff. Performance markings include *port.* (portamento) and *loco*. Dynamic markings include *(p)* (piano) and *(f)* (forte). The score includes various musical notations such as notes, rests, slurs, and articulation marks.

This musical score page, numbered 6, features eight staves of music. The instruments are: Flute (Fl.), Clarinet in Bass (Cl. b.), Trumpet (Tr.), Horn (Cor.), Violin (Vn.), Viola (Vc.), Percussion XII (P₂ XII.), and Vibraphone 1 (P₁ Vib. 1). The score is divided into three measures, with measure numbers 16, 17, and 18 indicated. The Flute and Clarinet parts include complex rhythmic patterns and slurs. The Trumpet and Horn parts feature sustained notes with slurs. The Violin and Viola parts have slurs and a 'port.' (portamento) marking. The Percussion XII and Vibraphone parts consist of rhythmic patterns with slurs. The key signature has one flat (B-flat), and the time signature is 4/4. The score includes various musical notations such as slurs, accents, and dynamic markings.

Poco più mosso

19 20 21

Fl.

Cl.b.

Tr.

Cor.

Vn.

Vc.

port.

port.

port.

arco

pizz.

pizz.

pizz.

13

8

P₂ XII.

P₁ Vib. 1

Cencs.

Musical score for measures 22-25. The score includes parts for Flute (Fl.), Clarinet (Cl.), Trumpet (Tr.), Horn (Cor.), Violin (Vn.), Viola (Vc.), Percussion (P1, P2), Xylophone (Xil.), Woodwinds (Wbls.), Vibraphone 1 (Vib.1), Vibraphone 2 (Vib.2), Piano (Ptti.), and Maracas (Mar.).

Measures 22-25 are marked with measure numbers 22, 23, 24, and 25. The Flute part includes accents and slurs. The Clarinet part includes the instruction *sempre*. The Horn part includes the instruction *sordina metálica*. The Violin and Viola parts include *arco*, *pizz.*, and *arco* markings. The Viola part includes *sempre* and *sf*. The Percussion part includes *loco*. The Maracas part includes *v* markings.

A blacked-out section of the score is present between measures 22 and 25, containing rhythmic notation with time signatures 10/8, 13/8, 6/8, and 13/8.

26 27 28

Fl.

Cl.b.

Tr.

Cor.

Vn. arco pizz. arco

Vc. pizz. arco pizz. sf sf

Detailed description: This block contains the musical notation for measures 26, 27, and 28 for six instruments. The Flute (Fl.) part starts in measure 26 with a quarter note G4, followed by quarter notes A4 and B4 in measure 27, and a quarter rest in measure 28. The Clarinet Bass (Cl.b.) part has a quarter rest in measure 26, followed by a quarter note G3 in measure 27, and a quarter note A3 in measure 28. The Trumpet (Tr.) part has a quarter rest in measure 26, followed by quarter notes G4 and A4 in measure 27, and quarter notes B4 and A4 in measure 28. The Cor Anglais (Cor.) part has a quarter rest in measure 26, followed by quarter notes G4 and A4 in measure 27, and quarter notes B4 and A4 in measure 28. The Violin (Vn.) part starts in measure 26 with a quarter note G4, followed by quarter notes A4 and B4 in measure 27, and quarter notes B4 and A4 in measure 28. The Viola (Vc.) part has a quarter rest in measure 26, followed by a quarter note G3 in measure 27, and a quarter note A3 in measure 28. Dynamics include *sf* (sforzando) and articulation includes *arco* (arco) and *pizz.* (pizzicato).

10 13 13

Detailed description: This block shows a percussion part with three measures. The first measure is marked with a '10' and contains a quarter note G2. The second measure is marked with a '13' and contains a quarter note A2. The third measure is marked with a '13' and contains a quarter note B2. The notes are on a grand staff with a treble clef.

P1

Xil.

Wbbs.

Vib.1

Cencs.

P2

Vib.2

Ptti.

Mar.

Bgs. Tomts.

Detailed description: This block contains the musical notation for two percussion parts, P1 and P2, across measures 26, 27, and 28. P1 includes Xylophone (Xil.), Woodblock (Wbbs.), Vibraphone 1 (Vib.1), and Congas (Cencs.). P2 includes Vibraphone 2 (Vib.2), Tom-toms (Ptti.), Maracas (Mar.), and Bongos/Toms (Bgs. Tomts.). The notation shows various rhythmic patterns and articulation marks for each instrument.

29 30 31 32

Fl.

Cl.b.

Tr.

Cor.

Vn.

Vc.

13 **10** **10** **12**

Xil.

Wbbs.

P₁ Vib.1

Cencs.

Vib.2

Ptti.

Mar.

P₂ Bgs. Tomts.

The musical score is arranged in a standard orchestral format. The top section includes Flute (Fl.), Clarinet in B-flat (Cl.b.), Trumpet (Tr.), Horn (Cor.), Violin (Vn.), and Viola (Vc.). The bottom section includes Xylophone (Xil.), Woodbass (Wbbs.), Percussion 1 (P₁) with Vibraphone 1 (Vib.1) and Cymbals (Cencs.), Percussion 2 (P₂) with Vibraphone 2 (Vib.2), PTTI (Ptti.), Maracas (Mar.), and Basses/Toms (Bgs. Tomts.).

Measures 29-32 are marked with measure numbers 29, 30, 31, and 32. A black bar highlights measures 29-32 with measure numbers 13, 10, 10, and 12. Performance markings include *f sempre* for the Horn, and *pizz.* and *arco* for the Violin and Viola. The Percussion 1 part includes accents and dynamic markings like *b*.

33 34 35 36

Fl.

Cl.b.

Tr.

Cor.

Vn. *pizz. arco* *sf* *pizz. arco* *sf* *pizz.* *arco*

Vc. *sf* *pizz.* *arco* *sf* *pizz.* *arco* *sf*

12 6 10 10

Xii.

Wbbs.

Vib. 1

Cencs.

Vib. 2

Ptti.

Mar.

Bgs. Tomts.

P₁

P₂

Fl. 37 38 39 40

Cl.b.

Tr.

Cor.

Vn.

Vc. pizz. arco

13 13 7 6

Xil.

Wbts.

Vib.1

Cencs.

Vib.2

Ptti.

Mar.

Bgs. Tomts.

1st

2nd

8

41 42 43 44 45

Fl.

Cl.b.

Tr.

Cor.

Vn.

Vc.

pizz. arco

sf

pizz. arco

sf

pizz. arco

sf

13 7 6 13 11

XII.

Wb1s.

Vib.1

Cencs.

Vib.2

1

Ptti.

Mar.

Bgs. Tomts.

P₁

P₂

Fl. 46 47 48 49 50

Cl. b.

Tr.

Cor.

Vn. *pizz.* *arco* *sf*

Vc. *pizz.* *arco* *sf*

6 7 12 13 6

Xii. *loco*

Wb. s.

Vib. 1

Cencs.

Vib. 2

Ptti.

Mar.

Bgs. Tomts.

P₁

P₂

51 52 53 54

Fl.

Cl.b.

Tr.

Cor.

Vn.

Vc.

14 10 8 11

Xii.

Wbbs.

Vib.1

Gencs.

Vib.2

Ptti.

Mar.

Bgs. Tomts.

pizz. arco

5f

55 56 57 58

Fl.

Cl.b.

Tr.

Cor.

Vn.

Vc.

10 10 13 13

XII.

Wbbs.

Vib.1

Cencs.

Vib.2

Pttl.

Mar.

Bgs. Tomts.

P_1

P_2

Detailed description: This page of a musical score covers measures 55 through 58. The instruments listed on the left are Flute (Fl.), Clarinet in B-flat (Cl.b.), Trumpet (Tr.), Cor Anglais (Cor.), Violin (Vn.), Violoncello (Vc.), Xylophone (XII.), Woodblock (Wbbs.), Vibraphone 1 (Vib.1), Cymbals (Cencs.), Vibraphone 2 (Vib.2), Tom-tom (Pttl.), Maracas (Mar.), and Bongos/Toms (Bgs. Tomts.). The woodwinds and strings have active parts with various articulations and dynamics. The strings include markings for 'pizz.' (pizzicato) and 'arco' (arco), with dynamic markings like 'sf' (sforzando). The percussion section includes a xylophone with rhythmic patterns of 10 and 13 strokes, and other instruments like woodblock, cymbals, and maracas. The score is divided into two parts, P1 and P2, indicated by brackets on the left. Measure numbers 55, 56, 57, and 58 are printed above the first four staves.

59 60 61 62

Fl.

Cl.b.

Tr.

Cor.

Vn.

Vc.

13

10

10

10

XII.

Wbts.

Vib.1

Cencs.

Vib.2

Ptti.

Mar.

Bgs. Tomts.

63 64 65

Fl.

Cl.b.

Tr.

Cor.

Vn. *pizz.* *arco* *sf*

Vc.

14 **14** **13**

Xii.

Wbts.

Vib.1

Cencs.

Vib.2

Ptti.

Mar.

Bgs. Tomts.

Detailed description of the musical score: This page contains measures 63, 64, and 65 of a musical score. The instruments listed are Flute (Fl.), Clarinet in B-flat (Cl.b.), Trumpet (Tr.), Horn (Cor.), Violin (Vn.), Viola (Vc.), Percussion (P), and Drums (Bgs. Tomts.). The percussion section includes Xii., Wbts., Vib.1, Cencs., Vib.2, Ptti., and Mar. The Violin and Viola parts feature performance markings: *pizz.* (pizzicato), *arco* (arco), and *sf* (sforzando). The Drums part has a blacked-out section with the numbers 14, 14, and 13, likely indicating a change in the drum pattern or a specific rhythmic instruction. The score is written in standard musical notation with treble and bass clefs, and various dynamics and articulation marks.

66 67 68

Fl.

Cl.b.

Tr.

Cor.

Vn.

Vc.

pizz. *arco*

16 7 20

XII.

Wb1s.

Vib. 1

Cencs.

Vib. 2

Ptti.

Mar.

Bgs. Tomts.

P₁

P₂

69 70 71 72

Fl.

Cl. b.

Tr.

Cor.

Vn.

Vc.

10 11 11 12

Xil.

Wbls.

Vib. 1

Cencs.

P₂

P₁

Musical score for page 21, measures 73-75. The score is arranged in a multi-staff format. The instruments listed are Fl. (Flute), Cl.b. (Bass Clarinet), Tr. (Trumpet), Cor. (Cor Anglais), Vn. (Violin), Vc. (Violoncello), Xil. (Xylophone), Wb1s. (Wagner Tubas), Vib.1 (Vibraphone), and Cencs. (Cymbals). The score includes various musical notations such as notes, rests, and dynamic markings. A blacked-out section with the number 13 is present between measures 75 and 76. The page number 21 is located in the top right corner.

76 77

Fl.

Cl.b.

Tr.

Cor.

Vn.

Vc.

20 10

Xil.

Wbts.

Vib.1

Cencs.

P₂

P₁

Musical score for Flute (Fl.), Clarinet (Cl.b.), Trumpet (Tr.), Cor, Violin (Vn.), and Viola (Vc.). The score is divided into two systems, 78 and 79. The Flute part starts with a measure rest of 78. The Clarinet part has a measure rest of 79. The Trumpet, Cor, Violin, and Viola parts have measure rests of 78 and 79. The score includes various musical notations such as notes, rests, and dynamic markings.

Percussion section with two measures. The first measure is marked with a 24 and the second measure is marked with a 14. The notation includes a bass drum and a snare drum.

Musical score for Xil., Wbts., Vib., and Cencs. The score is divided into two systems, P₂ and P₁. The Xil. part has a measure rest of 78. The Wbts. part has a measure rest of 79. The Vib. part has a measure rest of 78. The Cencs. part has a measure rest of 79. The score includes various musical notations such as notes, rests, and dynamic markings.

This musical score page contains the following elements:

- Measures:** The score is divided into measures 80, 81, and 82.
- Instruments:** Flute (Fl.), Clarinet in Bass (Cl. b.), Trumpet (Tr.), Horn (Cor.), Violin (Vn.), Viola (Vc.), Percussion (Perc.), and Cymbals (Cencs.).
- Groupings:** Percussion instruments are grouped into two sections: P₂ (Xil., Wbbs., Vib. 1) and P₁ (Cencs.).
- Tempo/Signature:** A black box highlights the tempo marking $\frac{14}{4}$ and the time signature $\frac{4}{4}$.
- Dynamic Markings:** A *pp* (pianissimo) marking is present in the Violin part.
- Performance Indicators:** Accents (^) are placed above many notes in the woodwind and string parts.

83 84

Fl.

Cl. b.

pp sempre

Tr.

Cor.

Vn.

Vc.

P₁ Vib. 1

P₂ Vib. 2

85 86

Fl.

Cl.b.

Tr.

Cor.

Vn.

Vc.

P₁ Vib.

P₂ Vib.

poco a poco crescendo

sordina de cartón tk

pp sempre

pizz. arco sul pont. pizz. arco sul pont.

con l'arco pp sempre

con l'arco pp sempre

Detailed description: This page of a musical score covers measures 85 and 86. The instruments are Flute (Fl.), Clarinet Bass (Cl.b.), Trumpet (Tr.), Cor Anglais (Cor.), Violin (Vn.), Viola (Vc.), and two Violas (P₁ Vib. and P₂ Vib.). The Flute and Clarinet Bass parts feature complex rhythmic patterns with slurs and accents. The Clarinet Bass part includes the instruction 'poco a poco crescendo'. The Cor Anglais part is marked 'sordina de cartón' and 'tk', with a 'pp sempre' dynamic. The Violin and Viola parts alternate between 'pizz.' (pizzicato) and 'arco sul pont.' (arco sul ponticello). The two Violas play 'con l'arco' (with the bow) and are marked 'pp sempre'. The score is written in a key with one flat and a 3/4 time signature.

87 88

Fl.

Cl. b.

Tr.

Cor.

Vn.

Vc.

P₁ Vib. 1

P₂ Vib. 2

sordina harmo

pp sempre

arco sul pont. pizz. arco sul pont. pizz. arco sul pont. pizz. arco sul pont.

poco a poco crescendo

The image shows a page of a musical score for measures 87 and 88. The score is arranged in a system with seven staves. The instruments are: Flute (Fl.), Clarinet Bb (Cl. b.), Trumpet (Tr.), Cor Anglais (Cor.), Violin (Vn.), Viola (Vc.), and Vibraphone 1 (P₁ Vib. 1) and Vibraphone 2 (P₂ Vib. 2). The Flute part is mostly silent. The Clarinet Bb part has a complex rhythmic pattern with many sixteenth notes. The Trumpet part has a few notes in measure 88 with the instruction 'sordina harmo' and 'pp sempre'. The Cor Anglais part has a rhythmic pattern similar to the Clarinet Bb. The Violin and Viola parts have a complex rhythmic pattern with many sixteenth notes and are marked with 'arco sul pont.' and 'pizz.'. The Viola part has a 'poco a poco crescendo' instruction. The Vibraphone parts have a simple rhythmic pattern.

89 90

Fl.

Cl. b.

Tr.

Cor.

Vn.

Vc.

P₁ Vib.

P₂ Vib.

poco a poco crescendo

pizz. *arco sul pont.*

Detailed description of the musical score: The score is for measures 89 and 90. The Flute part (Fl.) has a whole rest in both measures. The Clarinet Bb (Cl. b.) part features a complex rhythmic pattern of eighth and sixteenth notes, with a dynamic marking of *poco a poco crescendo*. The Trumpet (Tr.) part has a melodic line with a trill-like figure in measure 89 and a descending line in measure 90. The Cor Anglais (Cor.) part has a melodic line with a dynamic marking of *poco a poco crescendo*. The Violin (Vn.) part has a melodic line with a dynamic marking of *poco a poco crescendo* and includes performance instructions *pizz.* and *arco sul pont.*. The Viola (Vc.) part has a melodic line with a dynamic marking of *poco a poco crescendo* and includes performance instructions *pizz.* and *arco sul pont.*. The two Vibraphone parts (P₁ Vib. and P₂ Vib.) have sparse, block-like accompaniment.

91 92

Fl.

Cl.b.

Tr.

Cor.

Vn.

Vc.

P₁ Vib.1

P₂ Vib.2

pizz. arco sul pont. arco sul pont. arco norm. arco sul pont. arco norm. arco norm. arco norm.

f sempre

f sempre

poco a poco crescendo

baq. duras

baq. duras

pp

This musical score page contains the following parts and markings:

- Fl. (Flute):** Measures 93 and 94. Marking: *f sempre*.
- Cl.b. (Clarinet Bass):** Measures 93 and 94. Marking: *f sempre*.
- Tr. (Trumpet):** Measures 93 and 94. Marking: *senza sordina*.
- Cor. (Horn):** Measures 93 and 94. Marking: *senza sordina*.
- Vn. (Violin):** Measures 93 and 94.
- Vc. (Viola):** Measures 93 and 94.
- P₁ Vib.1 (Vibraphone 1):** Measures 93 and 94. Markings: *f*, *ff*, *pp*.
- P₂ Vib.2 (Vibraphone 2):** Measures 93 and 94. Markings: *pp*, *pp*, *f*, *f*.

This page of a musical score, numbered 31, contains eight staves of music for various instruments. The staves are labeled on the left as follows: Fl. (Flute), Cl.b. (Clarinet in B-flat), Tr. (Trumpet), Cor. (Horn), Vn. (Violin), Vc. (Viola), P₁ Vib. 1 (Violin 1), and P₂ Vib. 2 (Violin 2). The Flute and Clarinet parts feature complex, rapid passages with many slurs and accents. The Trumpet and Horn parts have fewer notes, with dynamic markings such as *p* (piano) and *f* (forte). The Violin and Viola parts also contain dense, fast-moving lines. The Violin 1 and Violin 2 parts are more sparse, with dynamic markings including *f*, *pp* (pianissimo), and *p*. A measure number '96' is printed above the Flute staff. The score is written in a standard musical notation with various clefs and time signatures.

This musical score page, numbered 32, features seven staves of music. The top six staves are for woodwinds and strings: Flute (Fl.), Clarinet in Bass (Cl. b.), Trumpet (Tr.), Horn (Cor.), Violin (Vn.), and Viola (Vc.). The bottom two staves are for Vibraphone (Vib. 1 and Vib. 2). The Flute and Clarinet parts are highly melodic and feature extensive slurs and ornaments. The Trumpet and Horn parts are more rhythmic and include dynamic markings such as *sordina straight*, *f*, *p*, and *pp*. The Violin and Viola parts are also melodic and include slurs. The Vibraphone parts are more rhythmic and include dynamic markings like *f*, *pp*, and *p*. The score is divided into two measures, 97 and 98, with a repeat sign at the end of measure 98.

This musical score page, numbered 33, contains seven staves of music. The instruments are: Flute (Fl.), Clarinet (Cl. b.), Trumpet (Tr.), Cor (Cob.), Violin (Vn.), Viola (Vc.), and two Vibraphone parts (Vib. 1 and Vib. 2). The Flute and Clarinet parts feature complex melodic lines with many slurs and accents, and a tempo marking of 100. The Trumpet and Cor parts have sparse, punctuated notes with dynamic markings like *p* and *f*. The Violin and Viola parts play more active, rhythmic patterns. The two Vibraphone parts provide harmonic support with sustained notes and dynamic markings such as *p*, *f*, and *pp*. The score is written in a standard musical notation style with various clefs and time signatures.

This musical score page, numbered 34, contains measures 101 and 102. The instruments are arranged as follows:

- Flutes (Fl.):** Measures 101 and 102 are marked with *f*. A dynamic change to *pp* occurs at the start of measure 102.
- Clarinets (Cl.b.):** Measures 101 and 102 are marked with *f*. A dynamic change to *pp* occurs at the start of measure 102.
- Trumpets (Tr.):** Measures 101 and 102 are marked with *f*. A dynamic change to *pp* occurs at the start of measure 102. The instruction "senza sordina" is written above the staff.
- Cor Anglais (Cor.):** Measures 101 and 102 are marked with *pp*. A dynamic change to *f* occurs at the start of measure 102.
- Violins (Vn.):** Measures 101 and 102 are marked with *f*. A dynamic change to *pp* occurs at the start of measure 102.
- Violas (Vc.):** Measures 101 and 102 are marked with *f*. A dynamic change to *pp* occurs at the start of measure 102.
- Vibraphone 1 (Vib.1):** Measures 101 and 102 are marked with *f*. A dynamic change to *pp* occurs at the start of measure 102.
- Vibraphone 2 (Vib.2):** Measures 101 and 102 are marked with *pp*. A dynamic change to *f* occurs at the start of measure 102.

The score includes various musical notations such as slurs, accents, and dynamic markings (*f*, *pp*) to guide the performance.

103

Fl.

Cl.b.

Tr.

Cor.

Vn.

Vc.

P₁ Vib.1

P₂ Vib.2

sordina straight

pp f

pp

pp

p

pp

f

ff

p

pp

f

pp

p

f

104

105

Fl.

106

Clarinetz.

Tr.

senza sordina

Cor.

Vn.

arco sul pont.

pizz. v

Vc.

pizz. arco norm.

Xyl.

Vib. 1

Vib. 2

Mar.

*P*₁

*P*₂

Detailed description: This page of a musical score covers measures 105 and 106. The instrumentation includes Flute (Fl.), Clarinet Bass (Cl. b.), Trumpet (Tr.), Cor Anglais (Cor.), Violin (Vn.), Violoncello (Vc.), Xylophone (Xyl.), Vibraphone (Vib. 1 and Vib. 2), and Maracas (Mar.).
 - **Flute:** Measures 105-106 feature a rapid sixteenth-note passage with slurs and accents. Measure 106 has a dynamic marking of *sf* and a performance instruction of "Flutterz."
 - **Clarinet Bass:** Mirrors the flute's melodic line, also with slurs and accents.
 - **Trumpet:** Measures 105-106 are marked "senza sordina". Measure 105 starts with a *pp* dynamic and an accent, moving to *f*. Measure 106 has a *sf* dynamic.
 - **Cor Anglais:** Provides harmonic support with notes in both staves, marked with *f* and *p*.
 - **Violin:** Measures 105-106 feature a sixteenth-note run. Measure 106 includes "arco sul pont." and "pizz. v".
 - **Violoncello:** Features a sixteenth-note run in measure 105, followed by "pizz. arco norm." in measure 106.
 - **Xylophone:** Remains silent in measure 105 and has a few notes in measure 106.
 - **Vibraphone 1:** Measures 105-106 feature a melodic line with slurs and accents, marked with *pp*, *f*, and *sf*.
 - **Vibraphone 2:** Measures 105-106 feature a melodic line with slurs and accents, marked with *f*, *p*, and *sf*.
 - **Maracas:** Remains silent in measure 105 and has a few notes in measure 106.
 - **Groupings:** The Xylophone and Vibraphone 1 are grouped under a bracket labeled *P*₁. Vibraphone 2 and Maracas are grouped under a bracket labeled *P*₂.

Flutterz.

107

108

Fl.

Cl.b.

Tr.

Cor.

Vn.

Vc.

XII.

Vib. 1

Vib. 2

Mar.

P₁

P₂

The musical score is arranged in a standard orchestral format. The top staves are for Flute (Fl.), Clarinet in B-flat (Cl.b.), Trumpet (Tr.), and Horn (Cor.). The middle staves are for Violin (Vn.) and Viola (Vc.). The bottom staves are for Percussion (P₁ and P₂), Vibraphone 1 (Vib. 1), Vibraphone 2 (Vib. 2), and Mallets (Mar.). The score is divided into two measures, 107 and 108. Measure 107 features a complex rhythmic pattern with various dynamics and articulations. Measure 108 continues the pattern with similar dynamics and articulations. The score includes a variety of dynamic markings such as *sf*, *p*, and *f*, and performance instructions such as "Flutterz.", "arco sul pont.", "pizz.", and "arco sul tasto".

109 110 Flatterz.

Fl.

Cl.b.

Tr. sordina straight

Cor.

Vn. arco sul pont. pizz. gliss. pizz.

Vc. arco norm. pizz. arco sul pont. gliss.

Xil. baq. duras

Vib.1 baq. blandas mp

Vib.2

Mar. p

P₁

P₂

Detailed description: This page of a musical score covers measures 109 and 110. The instruments are arranged in a standard orchestral layout. Measure 109 shows the beginning of the section with various instruments. Measure 110 is marked 'Flatterz.' and contains more complex rhythmic and melodic patterns. The woodwinds (Flute, Clarinet, Trumpet, Cor Anglais) play melodic lines with various articulations. The strings (Violin and Viola) play a rhythmic accompaniment with techniques like 'arco sul pont.' and 'pizz.'. The percussion section includes Xylophone (Xil.), Vibraphone (Vib.1 and Vib.2), and Maracas (Mar.), each with specific playing instructions like 'baq. duras' and 'baq. blandas'. Dynamics range from piano (p) to fortissimo (ff). The score is divided into two parts, P₁ and P₂, indicated by brackets on the left.

111 112

Fl. *p* Flatterz.

Cl.b. *p*

Tr. *p* senza sordina

Cor. *p* Flatterz.

Vn. arco norm. arco sul pont. arco sul tasto

Vc. pizz. arco sul tasto *gliss.*

P₁

Xil.

Vib.1 *mp* baq. blandas

Vib.2 *mp* baq. blandas

P₂

Mar.

113 *fp* 114

Fl.

Cl.b.

Tr.

Cor.

Vn.

Vc.

Xil.

Vib.1

Vib.2

Mar.

p *sf* *f* *sf* *f* *sf* *f* *sf* *f* *sf* *f* *sf*

arco sul pont. *pizz.* *arco norm.* *pizz.*

baq. duras.

P₁ *P₂*

115 Flatterz. 116 $b\flat$

Fl. *ff* Flatterz. *p*

Cl. b. *p* *f* *p*

Tr. Flatterz. *p*

Cor. *ff* *p*

Vn. arco norm. arco sul tasto

Vc. arco sul tasto *p*

Xii.

Vib. 1 *mp* baq. blandas

Vib. 2 *mp* baq. blandas

Mar.

117 118

Fl. Flatterz.

Cl.b.

Tr.

Cor. Flatterz.

Vn. arco norm.

Vc. pizz. arco norm.

XII.

P₁ Vib.1 baq. duras

Vib.2 baq. duras

P₂ Mar. p

Detailed description: This page of a musical score covers measures 117 and 118. The instruments are arranged in a standard orchestral layout. The Flute (Fl.) and Clarinet in B-flat (Cl.b.) parts are marked with 'Flatterz.' and dynamic markings of *sf* and *sfz*. The Trumpet (Tr.) and Cor Anglais (Cor.) parts also feature 'Flatterz.' markings. The Violin (Vn.) and Viola (Vc.) parts are marked with 'arco norm.' and dynamic markings of *p* and *f*. The Percussion (P₁) section includes a Xylophone (XII.) and Vibraphone 1 (Vib.1), both marked with 'baq. duras' and dynamic markings of *sf* and *sfz*. Vibraphone 2 (Vib.2) is also marked with 'baq. duras' and dynamic markings of *sf* and *sfz*. The Mallets (Mar.) part is marked with a dynamic of *p*. The score includes various musical notations such as slurs, ties, and dynamic hairpins.

119 120

Fl.

Cl.b.

Tr. *sordina straight*

Cor.

Vn. *arco sul tasto*

Vc. *arco sul tasto*

Xil.

Vib. 1 *baq. blandas* *p* *f* *mp*

Vib. 2 *baq. blandas* *mp*

Mar.

P₁

P₂

Detailed description: This page of a musical score covers measures 119 and 120. The instruments listed are Flute (Fl.), Clarinet Bass (Cl.b.), Trumpet (Tr.), Cor Anglais (Cor.), Violin (Vn.), Viola (Vc.), Xylophone (Xil.), Vibraphone 1 (Vib. 1), Vibraphone 2 (Vib. 2), and Maracas (Mar.). The score includes various performance instructions such as *arco sul tasto* for the strings and *sordina straight* for the trumpet. Dynamic markings include *p* (piano), *f* (forte), and *mp* (mezzo-piano). The score is divided into two parts, *P₁* and *P₂*, indicated by brackets on the left. Measure 119 begins with a key signature change to one flat (B-flat) and a common time signature. Measure 120 begins with a key signature change to one sharp (F#) and a common time signature. The Flute part has a *p* dynamic and a slur over measures 119-120. The Clarinet Bass part has a *p* dynamic and a slur over measures 119-120. The Trumpet part has a *p* dynamic and a slur over measures 119-120. The Cor Anglais part has a *p* dynamic and a slur over measures 119-120. The Violin and Viola parts have *arco sul tasto* markings and slurs over measures 119-120. The Xylophone part has a *p* dynamic and a slur over measures 119-120. The Vibraphone 1 part has *baq. blandas* markings and dynamics of *p*, *f*, and *mp* over measures 119-120. The Vibraphone 2 part has *baq. blandas* markings and a dynamic of *mp* over measures 119-120. The Maracas part has a *p* dynamic and a slur over measures 119-120.

121 122

Fl. *sf* *p*

Cl. b. *sf* *p*

Tr. *sf* *p* senza sordina

Cor. *sf* *p* arco sul tasto

Vn. *sf* *p* arco sul ponticello

Vc. *sf* *p* arco sul tasto

Xil. *p* *f* baq. duras

Vib. 1 *mp* baq. blandas

Vib. 2 *mp* baq. blandas

Mar. *mp* baq. duras

*P*₁

*D*₂

123 124

Fl.
Cl.b.
Tr.
Cor.
Vn.
Vc.
XII.
Vib.1
Vib.2
Mar.

p
f

Detailed description: This page of a musical score covers measures 123 and 124. The instruments are arranged in a standard orchestral layout. The Flute (Fl.) and Clarinet in B-flat (Cl.b.) parts feature melodic lines with slurs and accents. The Trumpet (Tr.) and Horn (Cor.) parts provide harmonic support with sustained notes and slurs. The Violin (Vn.) and Viola (Vc.) parts have melodic lines with slurs. The Harp (XII.) is marked with a piano (*p*) dynamic. The two Vibraphone parts (Vib.1 and Vib.2) and the Mallets (Mar.) are also present, with the Vibraphone parts showing melodic lines. The score includes various musical notations such as slurs, accents, and dynamic markings.

Musical score for measures 125 and 126. The score includes parts for Flute (Fl.), Clarinet in Bass (Cl. b.), Trumpet (Tr.), Cor Anglais (Cor.), Violin (Vn.), Viola (Vc.), Xylophone (Xil.), Vibraphone 1 (Vib. 1), Vibraphone 2 (Vib. 2), and Maracas (Mar.).

Measures 125 and 126 are marked at the top of the Flute staff. The Flute part begins with a sharp sign and a fermata over a whole note. The Clarinet part has a similar fermata. The Trumpet part has a whole note with a flat sign. The Cor Anglais part has a whole note with a sharp sign. The Violin and Viola parts have a whole note with a sharp sign. The Xylophone part has a whole rest. The Vibraphone 1 part has a whole note with a sharp sign. The Vibraphone 2 part has a whole note with a sharp sign. The Maracas part has a whole rest.

127 128

Fl. *sf* *p* Flatterz.

Cl. b. *f* *ff* *p*

Tr. *sf* *p*

Cor. *arco norm.* *p*

Vn. *arco sul pont.* *p*

Vc. *arco sul tasto* *p*

Xii.

Vib. 1 *f* *mp*

Vib. 2 *p* *f* *mp*

Mar.

*P*₁

*P*₂

Detailed description: This page of a musical score covers measures 127 and 128. The instruments and their parts are: Flute (Fl.) with dynamics *sf* and *p*, marked 'Flatterz.'; Clarinet in B-flat (Cl. b.) with dynamics *f*, *ff*, and *p*; Trumpet (Tr.) with dynamics *sf* and *p*; Horn (Cor.) with 'arco norm.' and *p*; Violin (Vn.) with 'arco sul pont.' and *p*; Viola (Vc.) with 'arco sul tasto' and *p*; Percussion (P₁) including Xii. and Vib. 1; and Percussion (P₂) including Vib. 2 and Mar. The score includes various musical notations such as slurs, hairpins, and dynamic markings.

Fl. Flatterz. 129 130

Cl.b. Flatterz.

Tr. sordina straight Flatterz. senza sordina

Cor. Flatterz. Flatt. Flatterz.

Vn. pizz. arco norm. arco sul pont. arco sul tasto

Vc. arco norm. pizz. arco norm.

XII. loco

Vib.1 baq. duras

Vib.2

Mar. baq. duras

Dynamic markings: *p*, *f*, *ff*, *sf*, *sfz*, *pp*, *ppp*, *ppp*.

Performance instructions: *Flatterz.*, *sordina straight*, *senza sordina*, *Flatt.*, *pizz.*, *arco norm.*, *arco sul pont.*, *arco sul tasto*, *loco*, *baq. duras*.

131 *f p* 132

Fl.

Cl.b.

Tr.

Cor.

Vn. arco sul tasto

Vc. *p*

Xil.

Vib.1 *mp* baq. blandas

Vib.2 *mp* baq. blandas

Mar.

*P*₁

*P*₂

Detailed description: This is a page of a musical score for measures 131 and 132. The score is arranged in a vertical stack of staves. The instruments and their parts are: Flute (Fl.), Clarinet in B-flat (Cl.b.), Trumpet (Tr.), Horn (Cor.), Violin (Vn.), Viola (Vc.), Xylophone (Xil.), Vibraphone 1 (Vib.1), Vibraphone 2 (Vib.2), and Maracas (Mar.). Measures 131 and 132 are indicated at the top. The Flute part has a dynamic marking of *f p* and a fermata. The Clarinet part has a dynamic marking of *p*. The Trumpet part has a dynamic marking of *p*. The Horn part has a dynamic marking of *p*. The Violin part has a dynamic marking of *p* and the instruction 'arco sul tasto'. The Viola part has a dynamic marking of *p*. The Xylophone part has a dynamic marking of *p*. The Vibraphone 1 part has a dynamic marking of *mp* and the instruction 'baq. blandas'. The Vibraphone 2 part has a dynamic marking of *mp* and the instruction 'baq. blandas'. The Maracas part has a dynamic marking of *p*. The score is divided into two systems, *P*₁ and *P*₂, indicated by brackets on the left.

133 *Flutterz.* 134

Fl. *p* *f* *p*

Cl.b. *sf* *p*

Tr. *sordina straight* *senza sordina* *p* *f*

Cor. *sf* *p*

Vn. *pizz.* *arco sul tasto* *p*

Vc. *arco norm.* *arco sul tasto* *p*

XII. *sf*

Vib.1 *baq. blandas* *ff* *mp*

Vib.2 *baq. duras* *baq. blandas* *sf* *p* *mp*

Mar.

Musical score for measures 135-138, featuring the following instruments:

- Fl. (Flute)
- Cl.b. (Clarinet Bass)
- Tr. (Trumpet)
- Cor. (Horn)
- Vn. (Violin)
- Vc. (Viola)
- P₁ Vib. 1 (Vibraphone 1)
- P₂ Vib. 2 (Vibraphone 2)

The score includes dynamic markings such as *p* and *pp*, and various musical notations including slurs, ties, and phrasing slurs. Measure numbers 135, 136, 137, and 138 are indicated at the top of the first system.

Musical score for measures 139-142, featuring the following instruments:

- Fl. (Flute)
- Cl.b. (Clarinet Bass)
- Tr. (Trumpet)
- Cor. (Cor Anglais)
- Vn. (Violin)
- Vc. (Viola)
- P₁ Vib.1 (Vibraphone 1)
- P₂ Vib.2 (Vibraphone 2)

The score is written in 2/4 time and includes various musical notations such as notes, rests, and dynamic markings. Measure numbers 139, 140, 141, and 142 are indicated at the top of the score.

This musical score page, numbered 53, covers measures 143 through 146. The instrumentation includes Flute (Fl.), Clarinet (Cl.b.), Trumpet (Tr.), Cor, Violin (Vn.), Viola (Vc.), and two Vibraphone parts (Vib. 1 and Vib. 2). The score is written in a key signature of one flat (B-flat) and a common time signature (C). Measure numbers 143, 144, 145, and 146 are clearly marked above the Flute staff. The Flute part features a melodic line with grace notes and slurs. The Clarinet part provides a harmonic accompaniment with slurs. The Trumpet part has a melodic line with slurs. The Cor part has a melodic line with slurs. The Violin and Viola parts have melodic lines with slurs. The two Vibraphone parts have melodic lines with slurs. The score includes various musical notations such as slurs, grace notes, and dynamic markings.

Musical score for measures 147 and 148. The score includes parts for Flute (Fl.), Clarinet in Bass (Cl. b.), Trumpet (Tr.), Cor Anglais (Cor.), Violin (Vn.), Viola (Vc.), Vibraphone 1 (Vib. 1), and Vibraphone 2 (Vib. 2). The Flute and Clarinet in Bass parts have notes marked with measure numbers 147 and 148. A double bar line is present between measures 147 and 148. A double-headed arrow is positioned below the Clarinet in Bass staff, spanning across the double bar line. The Vibraphone parts show rhythmic patterns in measures 147 and 148.

Sachsinger, Fred Jones 1991